

METALMASTER

BEAD ROLLING MACHINE OPERATION MANUAL



Model

MBR-610, MBR-1070

Product Code S633, Product Code S634

Edition No :MBR-012

Date of Issue :09/2019

www.machineryhouse.com.au



OPERATION MANUAL

MACHINE DETAILS

MACHINE	<input type="text" value="BEAD ROLLING MACHINE"/>
MODEL NO.	<input type="text"/>
SERIAL NO.	<input type="text"/>
DATE OF MANF.	<input type="text"/>

DISTRIBUTED BY



www.machineryhouse.com.au

www.machineryhouse.co.nz

Note:

This manual is only for your reference. Owing to the continuous improvement of the Metalmaster machine, changes may be made at any time without obligation or notice. Please ensure the local voltage is the same as listed on the specification plate before operating any electric machine.



NOTE:

In order to see the type and model of the machine, please see the specification plate. Usually found on the back of the machine. See example (Fig.1)

METALMASTER	
PRODUCT SPECIFICATION	
MODEL:	<input type="text"/>
CAPACITY:	<input type="text"/>
SER. NO:	<input type="text"/>
MFG DATE:	<input type="text"/>
WEIGHT:	<input type="text"/>
VOLTS:	<input type="text"/>
MOTOR Kw:	<input type="text"/>
www.machineryhouse.com.au Made in China	

FIG.1



OPERATION MANUAL

CONTENTS:

1. GENERAL MACHINE INFORMATION	
1.1 Specifications.....	4
1.2 Accessories.....	4
1.3 Identification.....	5
2. IMPORTANT INFORMATION	
2.1 Safety Requirements.....	7
2.2 Additional Safety For Bead Rolling Machine.....	9
3. SETUP	
3.1 Site Preparation.....	10
3.2 Clean - Up.....	10
3.3 Unpacking.....	10
3.4 Assembly.....	10
3.5 Electrical Installation.....	11
3.6 Full-Load Current Rating.....	11
4. OPERATION	
4.1 Mandrel Alignment.....	12
4.2 Adjusting The Fence Position.....	12
4.3 Speed Control.....	13
4.4 ON/OFF Switch.....	14
4.5 Foot Pedal & Emergency Stop.....	14
5. MAINTENANCE	
5.1 Schedule.....	15
5.2 Troubleshooting.....	15
5.3 AC Inverter Motor.....	15
SPARE PARTS.....	16
RISK ASSESSMENT SHEETS.....	21



OPERATION MANUAL

1.1 SPECIFICATIONS

CODE	S633	S634
MODEL	MBR-610	MBR-1070
Capacity (mm/Gauge)	1.2/18	1.2/18
Speed Range (R.P.M.)	0 -17	0 -17
Throat (mm)	610	1070
Guide Fence	Adjustable	Adjustable
Bead Mandrels Sizes (mm)	4, 6.35, 9.5, 12, 15	4, 6.35, 9.5, 12, 15
Flange Mandrels Sizes (mm)	1.6 ,3, 6.35, 9.5	1.6 ,3, 6.35, 9.5
Shearing Mandrel Quantity	1 Set	1 Set
Ogee Beading Mandrel Quantity	1 Set	1 Set
Wiring Mandrel Quantity	1 Set	1 Set
Power Required	240 Volts 50Hz	240 Volts 50Hz
Variable Speed Motor (Watts)	250	250
Motor Speed (R.P.M.)	1300	1300
Full Load Current (Amps)	1.8	1.8
Dimensions L x W x H (mm)	1080 x 610 x 1350	1540 x 800 x 1410
Shipping Dimensions L x W x H (mm)	1150 x 800 x 400	1700 x 950 x 400
Weight(kgs)	115	150

1.2 ACCESSORIES





OPERATION MANUAL

1.3 IDENTIFICATION

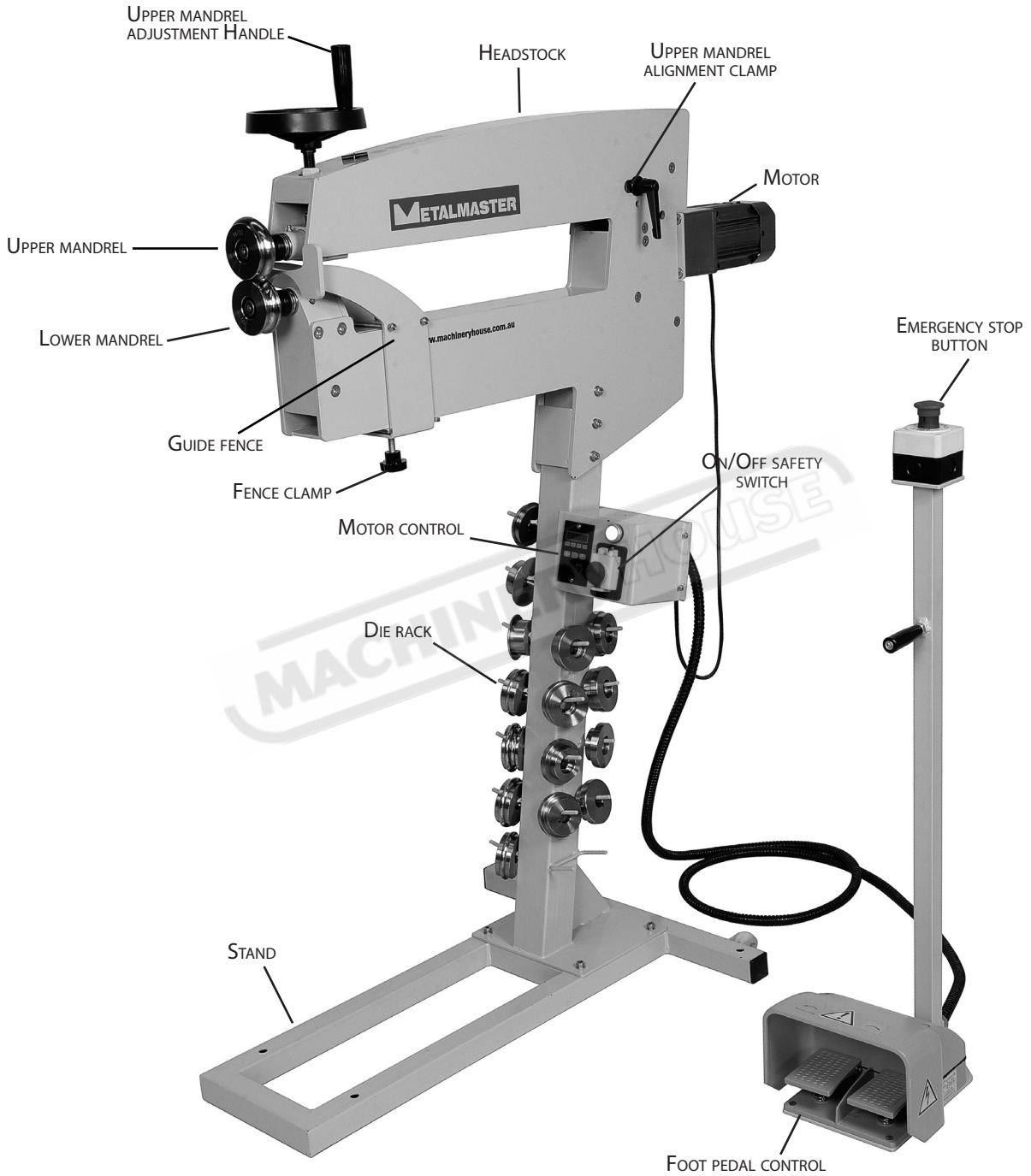

MBR-610 DISPLAYED

METALMASTER

OPERATION MANUAL

1.3 IDENTIFICATION CONT.



MBR-610 DISPLAYED

Controls

Refer to these control points and the following descriptions to become familiar with the basic controls and components of this machine. Understanding these items and how they work will help the operator understand the rest of the manual and help keep operators safe when operating this machine.

A. Lower Mandrel: This mandrel is fixed but driven. Rotates in the opposite direction to the upper mandrel.

B. Upper Mandrel: This mandrel is also driven and rotates in the opposite direction against the lower mandrel to shape workpiece as it advances through the mandrels. The upper mandrel is raised to remove the workpiece, and lowered against workpiece with moderate pressure during operations.

C. Upper Mandrel Elevation Crank: Rotates clockwise to lower the upper mandrel, and rotates counterclockwise to raise it.

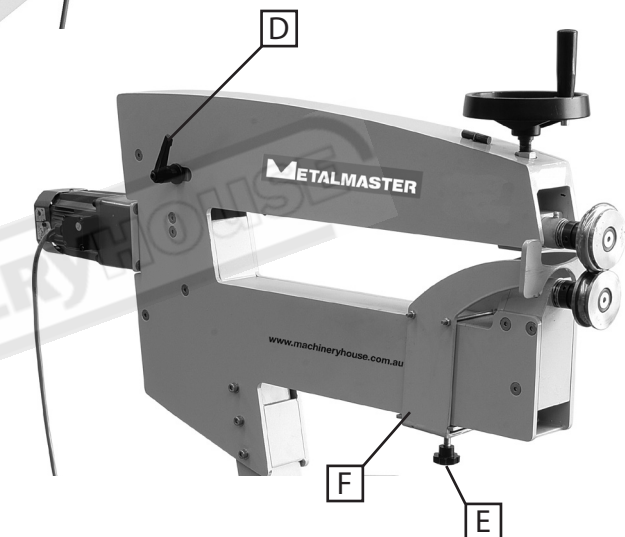

D. Upper Mandrel Alignment Clamps: When unclamped allows for adjustment to the lateral alignment of upper mandrel to the lower mandrel. Once alignment is made then both clamps are secured.

E. Fence Clamp: Tighten to lock the fence in position. Loosen to allow for the fence adjustment.

F. Fence: Guides the workpiece when rolling straight beads parallel to a workpiece edge.



OPERATION MANUAL

2.1 SAFETY REQUIREMENTS

DO NOT use this machine unless you have read this manual or have been instructed in the use of this machine in its safe use and operation



WARNING

This manual provides safety instructions on the proper setup, operation, maintenance, and service of this machine. Save this manual, refer to it often, and use it to instruct other operators. Failure to read, understand and follow the instructions in this manual may result in fire or serious personal injury—including amputation, electrocution, or death.

The owner of this machine is solely responsible for its safe use. This responsibility includes, but is not limited to proper installation in a safe environment, personnel training and authorization to use, proper inspection and maintenance, manual availability and comprehension, of the application of the safety devices, integrity, and the use of personal protective equipment.

The manufacturer will not be held liable for injury or property damage from negligence, improper training, machine modifications or misuse.



Safety glasses must be worn at all times in work areas. Earmuffs should be worn if the work area is noisy.



Sturdy footwear must be worn at all times in work areas.



Gloves should NOT be worn when operating machinery.



Long and loose hair must be contained with a net or under a hat

OWNER'S MANUAL. Read and understand this owner's manual before using the machine.

DISCONNECT POWER FIRST. If using power, always disconnect the machine from power supply before making adjustments, or servicing the machine. This prevents any risk of injury from unintended startup or contact with live electrical equipment

TRAINED OPERATORS ONLY. Operators that have not been trained have a higher risk of being seriously injured. Only allow trained or supervised people to use this machine. When the machine is not being used, disconnect the power, to the machine to prevent unauthorized use—especially around children. Make the workshop safe.



OPERATION MANUAL

2.1 SAFETY REQUIREMENTS Cont.

WEARING PROPER APPAREL. Do not wear clothing, apparel or jewelry that can become entangled in moving parts. Always tie back or cover long hair. Wear non-slip footwear to avoid accidental slips, which could cause loss of operating control.

HEARING PROTECTION. Always wear hearing protection when operating or observing loud machinery. Extended exposure to this noise without hearing protection can cause permanent hearing loss.

REMOVE ADJUSTING TOOLS. Tools left on machinery can become dangerous projectiles upon startup. Never leave hex keys, wrenches, or any other tools on machine. Always verify removal before starting!

USE CORRECT TOOL FOR THE JOB. Only use this tool for its intended purpose. Do not force the machine or its attachments to do a job for which they were not designed. Never make unapproved modifications. Modifying the machine or using it differently than intended may result in malfunction or mechanical failure that can lead to personal injury or death!

AWKWARD POSITIONS. Keep proper footing and balance at all times when operating machine. Do not overreach! Avoid awkward hand positions that make operating control difficult. This could increase the risk of accidental injury

GUARDS & COVERS. Guards and covers reduce accidental contact with moving parts or flying debris. Make sure they are properly installed, undamaged, and working correctly.

FORCING MACHINERY. Do not force the machine. It will do the job safer and better at the rate for which it was designed.

NEVER STAND ON MACHINE. Serious injury may occur if the machine is tipped or if the cutting tool is unintentionally contacted

STABLE MACHINE. Unexpected movement during operation greatly increases risk of injury or loss of control. Before starting, verify machine is stable and if using a mobile base it is locked in position.

UNATTENDED OPERATION. To reduce the risk of accidental injury, turn the machine OFF and ensure all moving parts have completely stopped before walking away. Never leave the machine running while unattended.

MAINTAIN WITH CARE. Follow all maintenance instructions and lubrication schedules to keep the machine in good working condition. A machine that is improperly maintained could malfunction, leading to serious personal injury or death.

CHECK DAMAGED PARTS. Regularly inspect the machine for any condition that may affect the safe operation. Immediately repair or replace damaged or parts that are incorrectly fitted before operating.

CHILDREN & BYSTANDERS. Keep children and bystanders at a safe distance from the work area. Stop using machine if they become a distraction.



OPERATION MANUAL

2.2 ADDITIONAL SAFETY FOR BEAD ROLLING MACHINE

DO NOT use this machine unless you have read the manual or have been trained and assessed to a competent level in its safe use and operation.



Safety glasses must be worn when operating this equipment



Long and loose hair must be contained when operating this equipment.



Safety footwear must be worn when operating this equipment



Close fitting/protective clothing must be worn when operating the machine



Dust mask must be worn when operating in high dust areas.



Hearing protection must be used when operating in a noisy environment

PRE-OPERATIONAL SAFETY CHECKS

- Locate and ensure you are familiar with all machine operations and controls.
- Ensure all guards are fitted, secure and functional. Do not operate if guards are missing or faulty.
- Working parts should be well lubricated and the dies are free of rust and dirt.
- Check workspaces and walkways to ensure no slip/trip hazards are present.
- Be aware of other people in the area and ensure the area is clear before using equipment.

OPERATIONAL SAFETY CHECKS

- Adjust the chosen dies slowly and in small adjustments.
- Take care during the initial feeding of the workpiece into the dies.
- Hold the workpiece sufficiently far back from the edge being fed into the dies, to allow for the infeed speed of the machine.
- Wind handle at a slow even rate. Be aware of rotating dies
- Only one person may operate this machine at any one time.

ENDING OPERATIONS AND CLEANING UP

- Ensure the machine is left in a safe condition after use.
- Leave the work area in a safe, clean and tidy state.

POTENTIAL HAZARDS AND INJURIES

- Sharp edges and burrs.
- Crush and pinch points.
- Hair/clothing getting caught in moving machine parts.
- Operator's hands may be caught and drawn into the rotating dies.

DON'T

- Do not use faulty equipment. Immediately stop and repair suspect machinery.
- Do not attempt to form material beyond the capacity of the machine.



OPERATION MANUAL

3. SETUP

3.1 SITE PREPARATION

When selecting the site for the machine, consider the largest size of workpiece that will be processed through the machine and provide enough space around the machine for operating the machine safely. Consideration should be given to the installation of auxiliary equipment. Leave enough space around the machine to open or remove doors/covers as required for the maintenance and service as described in this manual.

It is recommended that the machine is anchored to the floor to prevent tipping or shifting. It also reduces vibration that may occur during operation. The machine should be mounted on a reinforced concrete floor with a minimum of 150mm thickness. The floor must be able to support the weight of the machine and any workpiece that is to be worked.

3.2 CLEAN - UP

The unpainted surfaces of the machine have been coated with a waxy oil to protect them from corrosion during shipment. Remove the protective coating with a solvent cleaner or a citrus based degreaser.

Optimum performance from your machine will be achieved when you clean all moving parts or sliding contact surfaces that are coated with rust prevented products.

Hafco advise to avoid chlorine based solvents, such as acetone or brake parts cleaner, as they will damage painted surfaces and strip metal should they come in contact. Always follow the manufacturer's instructions when using any type of cleaning product.

3.3 UNPACKING

This machine was carefully packaged for safe transport. When unpacking, separate all enclosed items from packaging materials and inspect them for shipping damage. If items are damaged, please contact your distributor.

NOTE: Save all the packaging materials until you are completely satisfied with the machine and have resolved any issues with the distributor, or the shipping agent.

When unpacking, check to make sure that all parts shown on page 4 are included. If any parts are missing or broken, please contact the your distributor.

3.4 ASSEMBLY

The Motor (Transmission included) and Double Directions Foot Switch come pre-assembled to the Frame. For additional information regarding the parts, refer to the Spare Parts section.

To assemble the machine

1. Place the Stand (40#) on the floor.
2. Connect the Leg (75#) and the Frame (1#) with six Screws (48#), six Spring Washers (52#) and six Washers (53#).
3. Place the Frame Assembly on the Stand (40#) with four Screws (48#), four Spring Washers (52#) and four Washers (53#).



OPERATION MANUAL

3.5 ELECTRICAL INSTALLATION

Place the machine near an existing power source. Make sure all power cords are protected from traffic, material handling, moisture, chemicals, or other hazards. Make sure there is access to a means of disconnecting the power source. The electrical circuit must meet the requirements for 240 Volts.

NOTE : The use of an extension cord is not recommended as it may decrease the life of electrical components on your machine.

ELECTRICAL REQUIREMENTS

Nominal Voltage.....	240V
Cycle.....	50 Hz
Phase.....	Single Phase
Power Supply Circuit.....	10 Amps
Full Load Current.....	1.8 Amps

(Full load current rating is also on the specification plate on the motor.)

3.6 FULL-LOAD CURRENT RATING

The full-load current rating is the amperage a machine draws at when running at 100% of the output power. Where machines have more than one motor, the full load current is the amperage drawn by the largest motor or a total of all the motors and electrical devices that might operate at one time during normal operations.

Full-Load Current Rating for this machine at 240V is 1.6 Amps

It should be noted that the full-load current is not the maximum amount of amps that the machine will draw. If the machine is overloaded, it will draw additional amps beyond the full-load rating and if the machine is overloaded for a long period of time, damage, overheating, or fire may be caused to the motor and circuitry.

This is especially true if connected to an undersized circuit or a long extension lead. To reduce the risk of these hazards, avoid overloading the machine during operation and make sure it is connected to a power supply circuit that meets the requirements.



4. OPERATION

4.1 MANDREL ALIGNMENT

Before operations, and whenever you change the die sets, always make sure the mandrels are aligned to ensure properly formed beads. (Fig.4.1)

To align the mandrels,

1. Lower the upper mandrel until it almost touches the lower mandrel.
2. Loosen the upper mandrel lock levers ("D" in Fig. 4.2), and move the upper mandrel in or out until the upper mandrel die aligns with the lower mandrel die, then tighten the alignment clamps

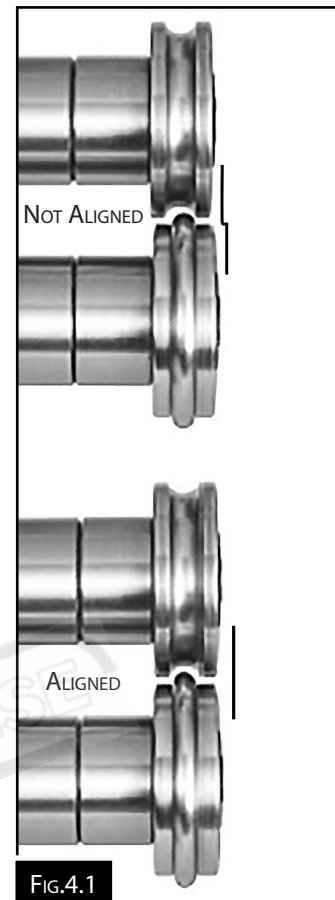
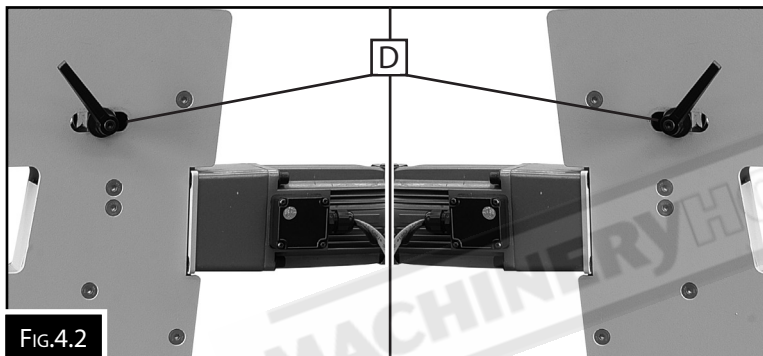

4.2 ADJUSTING THE FENCE POSITION

To create straight, consistent beads that are parallel with an edge of the workpiece, the fence is used to guide the workpiece in a straight line at a set distance from the mandrel dies.

To adjust the fence, loosen the clamp, then move the fence toward or away from the mandrel dies as needed, then re-tighten the clamp. (Fig.4.3)

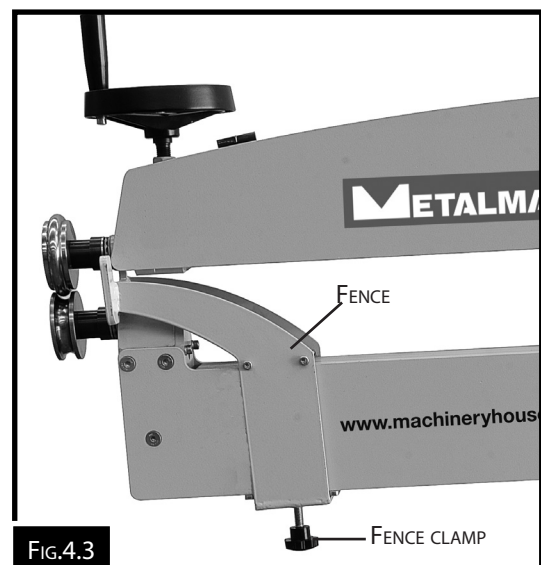



OPERATION MANUAL

4.3 SPEED CONTROL

The machine is fitted with an AC variable speed inverter motor which is controlled in three ways.

1. **ON/ OFF Switch.** Switches ON or OFF the power circuit in the machine. (Fig.4.6) ("B" in Fig.4.4)
2. **Power Lamp.** Is illuminated when power is connected to the machine ("A" in Fig.4.4)
3. **Foot Pedal.** Starts the mandrels turning and selects the direction of rotation.

NOTE: item "C" in Fig.4.4 controls the AC inverter motor and the parameters are set in the factory and locked. The parameters should only be changed by a factory service engineer.

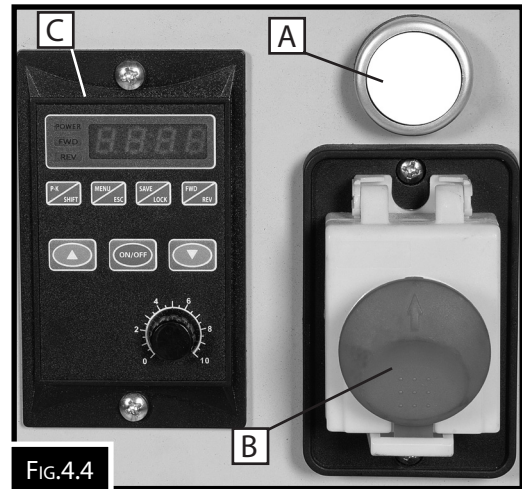

FIG.4.4

"C" CONTROLS

- A. Power light is illuminated when the power is switched on.
- B. FWD will flash as it memorizes the last direction the rolls traveled. When the forward pedal is pressed the FWD light stays illuminated indicating the rolls are moving in a forward direction.
- C. REV will flash as it memorizes the last direction the rolls traveled. When the reverse pedal is pressed the REV light stays illuminated indicating the rolls are moving in a reverse direction.
- D. Displays the speed of the rolls in Hz
- E. None of these buttons are used or need to be adjusted during normal operation of the machine. They are only used by service engineers to access the parameters for the AC inverter motor.
- F. The dial is used to set the speed of the rolls

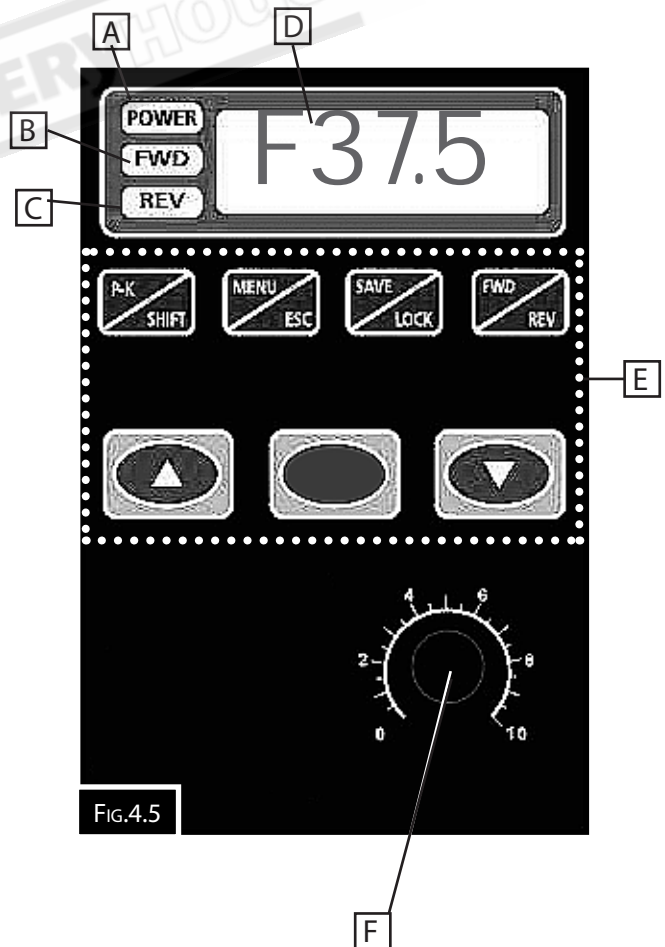

FIG.4.5

4.4 ON/OFF SWITCH

The ON/OFF safety switch is located on the front of the machine for quick, easy and safe access. The switch is fitted with a yellow door with a RED button in the centre of it.

To start the machine the yellow door needs to be released by pressing against the catch (Fig.4.6) to open it and reveal the green ON and RED stop buttons.

Push the bottom green button (A) to turn the machine ON. Push the top red button (B) to turn the machine OFF. (Fig.4.7)

In an emergency the red button on the yellow door can be pressed and held with the catch and the machine will stop. With the door closed the machine cannot be started until the catch is released and the buttons exposed.

CAUTION: Never walk away from the machine while it is still running. Always lock the switch in the Off position and unplug from the power supply when not in use.

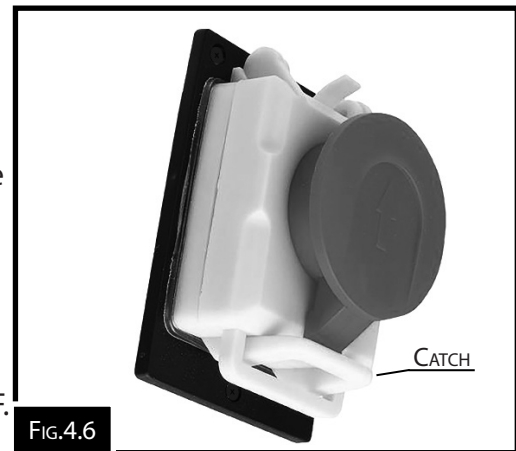

FIG.4.6

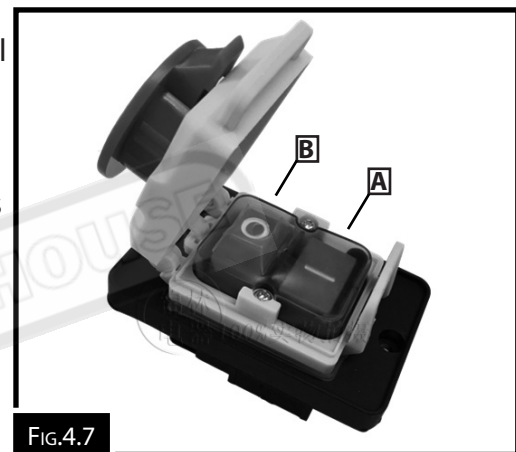

FIG.4.7

4.5 FOOT PEDAL & EMERGENCY STOP

Controls the forward and reverse direction of the mandrels. (Fig.4.8)

Can be moved to any position for ease of operation.

Depress the pedal to start the rotation. Once the pedal is released the mandrels will stop.

On the top of the stand is the emergency stop button.

When pressed the machine will stop. Before the machine will restart the emergency button needs to be twisted to release the stop button.



FIG.4.8



OPERATION MANUAL

5. MAINTENANCE

5.1 SCHEDULE

1. Clean the Transmission of dirt and debris after 250 hours of use.
2. Lubricate the Copper Bushing periodically.
3. Replace the grease in the Worm Gear Box every 2 years.

5.2 TROUBLESHOOTING

Symptom	Possible Cause	Possible Solution
Machine does not start or a breaker trips.	<ol style="list-style-type: none"> 1. Main power switch in OFF position at fault. 2. Plug/receptacle at fault/wired wrong 3. Incorrect power supply voltage/ circuit size. 4. Power supply circuit breaker tripped or blown fuse 5. Motor wires connected incorrectly. 6. Motor at fault. 7. Emergency Stop button not released. 	<ol style="list-style-type: none"> 1. Switch to ON position. Replace. 2. Test for good contacts; correct the wiring. 3. Ensure correct power supply voltage/ circuit size. 4. Ensure circuit is sized correctly and free of shorts. Reset circuit breaker 5. Correct motor wiring connections. 6. Test/repair/replace. 7. Release Emergency Stop button by twisting the button
Machine stalls or is underpowered	<ol style="list-style-type: none"> 1. Machine undersized for task. 2. Wrong workpiece material. 3. Motor overheated. 4. Motor wired incorrectly. 5. Plug/receptacle at fault. 6. Foot pedal switch at fault. 7. Motor bearings at fault. 	<ol style="list-style-type: none"> 1. Reduce downward pressure of upper roller. 2. Use correct type/size of sheet metal stock. 3. Clean motor, let cool, and reduce workload. 4. Wire motor correctly. 5. Test for good contacts/correct wiring. 6. Test/replace switch. 7. Test and replace
Workpiece deforms, kinks, or is crushed during operation	<ol style="list-style-type: none"> 1. Excessive rolling pressure. 2. Mandrel dies not properly aligned. 3. Mandrel die (s) are damaged. 	<ol style="list-style-type: none"> 1. Reduce downward pressure of upper mandrel. 2. Align mandrel dies 3. Replace mandrel die(s)
Workpiece does not move when rollers rotate.	<ol style="list-style-type: none"> 1. Not enough rolling pressure. 2. Grease/oil on workpiece/mandrel dies, causing dies to slip against work piece. 	<ol style="list-style-type: none"> 1. Increase down pressure of upper mandrel. 2. Thoroughly clean workpiece/mandrel dies to prevent slipping

AC INVERTER MOTOR

The machine is fitted with a controller that controls the operations of the machine including the speed of the machine through an AC inverter motor. In order to understand the function of the Inverter and ensure the safety of the user, please read and follow the instructions as detailed in this manual. When operating the machine if any abnormal problem is found that is not covered in this operating manual, please contact your local distributor and our service engineers will solve the problem for you.

METALMASTER

OPERATION MANUAL

NOTE: The AC motor fitted to this machine, is an electronic power device. For safety reasons please note the paragraphs containing **Caution** and **Warning** symbols in this section. They are important safety precautions to observe when, transporting, installing, and when operating and servicing the AC unit.

NOTE: The parameters for the AC inverter motor have been set at the factory and should not need to be touched. If changes need to be made they should be only be changed by a Hafco technician

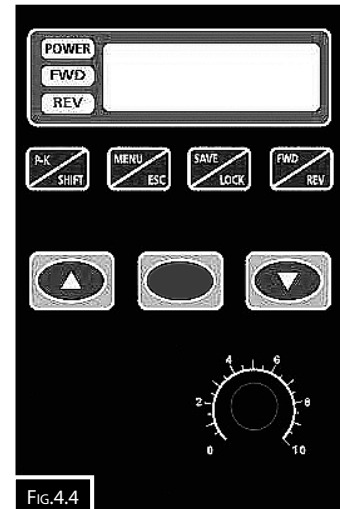

WARNING

- Do Not:** Touch the PCB or components on the PCB (printed circuit board) before the charging indicator light has gone out.
- Do Not:** Attempt to wire or check the circuitry, or component signals on the PCB when the power is switched ON.
- Do Not:** Attempt to disassemble or modify internal circuitry, wiring or components of the inverter.
- Do Not:** Use the machine if the earthing cable is disconnect from the inverter and the machine. The earthing cable must be connected at all time when being used.

CAUTION

- Do Not:** Attempt to perform dielectric strength tests to the internal components of the inverter unit. There are sensitive semi-conductor devices that are vulnerable to high voltage in the inverter
- Do Not:** Connect the output terminals (T1), (T2) and (T3) to the AC power unit.
- Do Not:** Make contact between the inverter with the primary PCB board. The CMOS IC is Vulnerable to static electrical charges.

SPARE PARTS

The following section covers the spare parts diagrams and lists that were current at the time this manual was originally printed. Due to continuous improvements of the machine, changes may be made at any time without notification.

HOW TO ORDER SPARE PARTS

1. Have your machines model number, serial number & date of manufacture on hand, these can be found on the specification plate mounted on the machine
2. A scanned copy of your parts list/diagram with required spare part/s identified
3. Go to www.machineryhouse.com.au/contactus and fill out the enquiry form attaching a copy of scanned parts list.



OPERATION MANUAL

SPARE PARTS DIAGRAM MBR-610

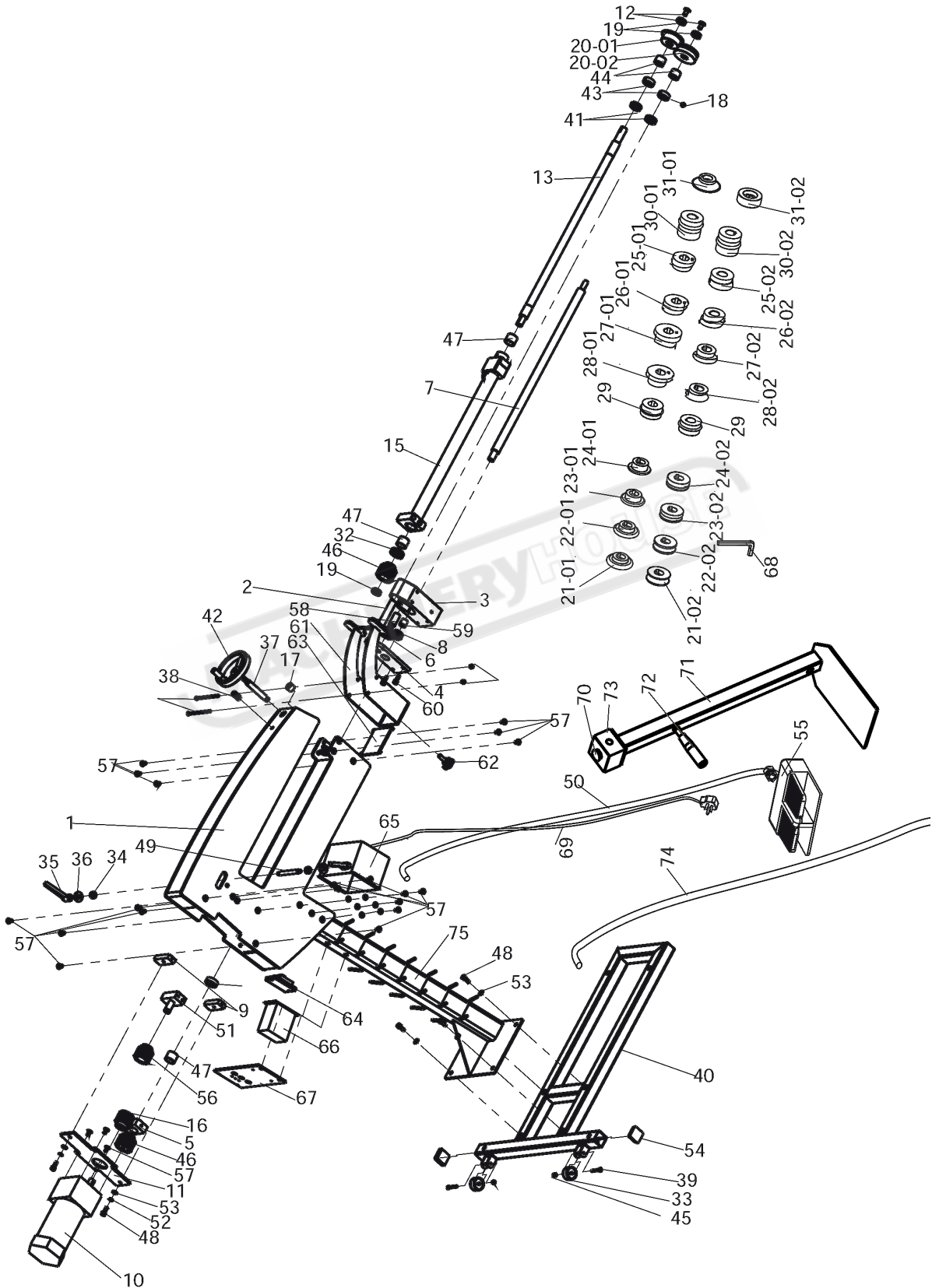



OPERATION MANUAL

SPARE PARTS LIST MBR-610

Part No.	Description	Qty.	Part No.	Description	Qty.
1	Frame for MBR-610	1	33	Wheel	2
2	Gear	1	34	Washer	2
3	Shaft Seat	1	35	Lock Handle	2
4	Shaft Seat Cover	1	36	Washer	2
5	Shaft Seat	1	37	Threaded Rod	1
6	Gear T21m2	1	38	Long Nut M6	1
7	Driving Shaft	1	39	Bolt M6X40	2
8	Gear T14m2	1	40	Stand	1
9	Plate	2	41	Bearing 51104	2
10	Motor	1	42	Handwheel	1
11	Square Plate	1	43	Collar	2
12	Screw M10X20	2	44	Spacer	2
13	Upper Shaft	1	45	Nut M6	2
14	Bushing	2	46	Gear T25m2	2
15	Upper Shaft Bushing	1	47	Bushing	3
16	Gear T23m2	1	48	Screw M8X20	12
17	Pressing Clamp	1	49	Shaft	1
18	Screw M8X8	6	50	Foot Switch Cable	1
19	Fixing Washer	3	51	Base Fixing Gear	1
20-01	Bead Roller Die 5/32"A	1	52	Spring Washer 8mm	12
20-02	Bead Roller Die 5/32"B	1	53	Washer 8mm	12
21-01	Bead Roller Die 1/4"A	1	54	Casing Cap	2
21-02	Bead Roller Die 1/4"B	1	55	Foot Switch	1
22-01	Bead Roller Die 3/8"A	1	56	Gear T23m2	1
22-02	Bead Roller Die 3/8"B	1	57	Screw M8X16	20
23-01	Bead Roller Die 15/32"A	1	58	Shaft	1
23-02	Bead Roller Die 15/32"B	1	59	Bushing	1
24-01	Bead Roller Die 19/32"A	1	60	Screw M6X20	4
24-02	Bead Roller Die 19/32"B	1	61	Guide Fence	1
25-01	Flange Roller Die	1	62	Knob	1
25-02	Flange Roller Die	1	63	Plate	1
26-01	Flange Roller Die 1/8"A	1	64	Safe Switch	1
26-02	Flange Roller Die 1/8"B	1	65	Switch Box	1
27-01	Flange Roller Die 1/4"A	1	66	Speed Change Device	1
27-02	Flange Roller Die 1/4"B	1	67	Box	1
28-01	Flange Roller Die 3/8"A	1	68	Hex Key Wrench 6mm	1
28-02	Flange Roller Die 3/8"B	1	69	Power Cable	1
29	Shearing Die	2	70	Emergency Stop	1
30-01	Ogee Beading Die A	1	71	Stand	1
30-02	Ogee Beading Die B	1	72	Handle	1
31-01	Wiring Die A	1	73	Emergency Stop Box	1
31-02	Wiring Die B	1	74	PVC Coated Steel Conduit	1
32	Bearing 51105	2	75	Leg	1



OPERATION MANUAL

SPARE PARTS DIAGRAM MBR-1070

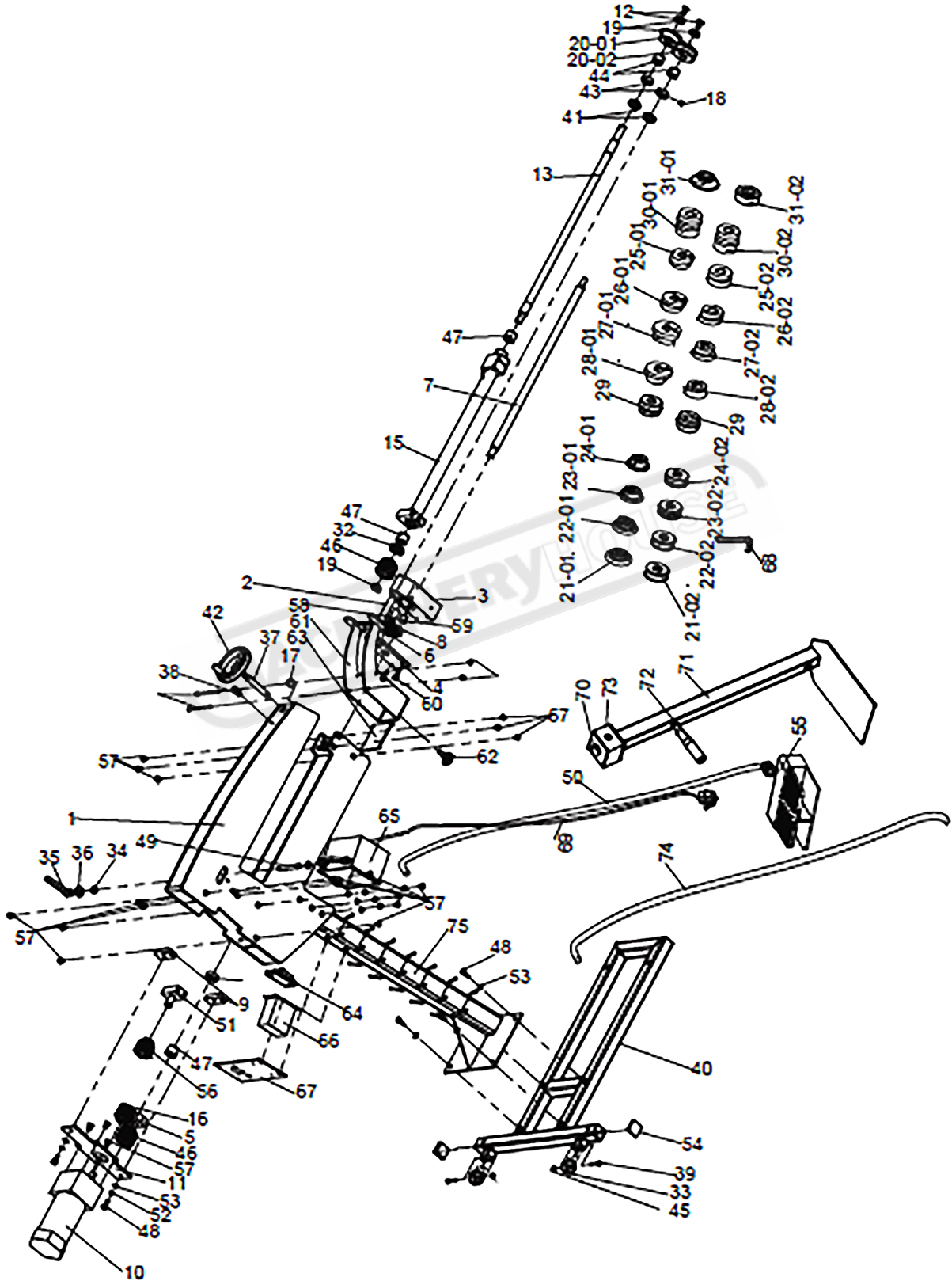



OPERATION MANUAL

SPARE PARTS LIST MBR-1070

Part No.	Description	Qty.	Part No.	Description	Qty.
1	Frame For MBR-1070	1	33	Wheel	2
2	Gear	1	34	Washer	2
3	Shaft Seat	1	35	Lock Handle	2
4	Shaft Seat Cover	1	36	Washer	2
5	Shaft Seat	1	37	Threaded Rod	1
6	Gear T21m2	1	38	Long Nut M6	1
7	Driving Shaft	1	39	Bolt M6X40	2
8	Gear T14m2	1	40	Stand	1
9	Plate	2	41	Bearing 51104	2
10	Motor	1	42	Handwheel	1
11	Square Plate	1	43	Collar	2
12	Screw M10X20	2	44	Spacer	2
13	Upper Shaft	1	45	Nut M6	2
14	Bushing	2	46	Gear T25m2	2
15	Upper Shaft Bushing	1	47	Bushing	3
16	Gear T23m2	1	48	Screw M8X20	12
17	Pressing Clamp	1	49	Shaft	1
18	Screw M8X8	6	50	Foot Switch Cable	1
19	Fixing Washer	3	51	Base Fixing Gear	1
20-01	Bead Roller Die 5/32"A	1	52	Spring Washer 8mm	12
20-02	Bead Roller Die 5/32"B	1	53	Washer 8mm	12
21-01	Bead Roller Die 1/4"A	1	54	Casing Cap	2
21-02	Bead Roller Die 1/4"B	1	55	Foot Switch	1
22-01	Bead Roller Die 3/8"A	1	56	Gear T23m2	1
22-02	Bead Roller Die 3/8"B	1	57	Screw M8X16	20
23-01	Bead Roller Die 15/32"A	1	58	Shaft	1
23-02	Bead Roller Die 15/32"B	1	59	Bushing	1
24-01	Bead Roller Die 19/32"A	1	60	Screw M6X20	4
24-02	Bead Roller Die 19/32"B	1	61	Guide Fence	1
25-01	Flange Roller Die	1	62	Knob	1
25-02	Flange Roller Die	1	63	Plate	1
26-01	Flange Roller Die 1/8"A	1	64	Safe Switch	1
26-02	Flange Roller Die 1/8"B	1	65	Switch Box	1
27-01	Flange Roller Die 1/4"A	1	66	Speed Change Device	1
27-02	Flange Roller Die 1/4"B	1	67	Box	1
28-01	Flange Roller Die 3/8"A	1	68	Hex Key Wrench 6mm	1
28-02	Flange Roller Die 3/8"B	1	69	Power Cable	1
29	Shearing Die	2	70	Emergency Stop	1
30-01	Ogee Beading Die A	1	71	Stand	1
30-02	Ogee Beading Die B	1	72	Handle	1
31-01	Wiring Die A	1	73	Emergency Stop Box	1
31-02	Wiring Die B	1	74	PVC Coated Steel Conduit	1
32	Bearing 51105	2	75	Leg	1



WARNING

General Machinery Safety Instructions

Machinery House
requires you to read this entire Manual before using this machine.

- 1. Read the entire Manual before starting machinery.** Machinery may cause serious injury if not correctly used.
- 2. Always use correct hearing protection when operating machinery.** Machinery noise may cause permanent hearing damage.
- 3. Machinery must never be used when tired, or under the influence of drugs or alcohol.** When running machinery you must be alert at all times.
- 4. Wear correct Clothing.** At all times remove all loose clothing, necklaces, rings, jewelry, etc. Long hair must be contained in a hair net. Non-slip protective footwear must be worn.
- 5. Always wear correct respirators around fumes or dust when operating machinery.** Machinery fumes & dust can cause serious respiratory illness. Dust extractors must be used where applicable.
- 6. Always wear correct safety glasses.** When machining you must use the correct eye protection to prevent injuring your eyes.
- 7. Keep work clean and make sure you have good lighting.** Cluttered and dark shadows may cause accidents.
- 8. Personnel must be properly trained or well supervised when operating machinery.** Make sure you have clear and safe understanding of the machine you are operating.
- 9. Keep children and visitors away.** Make sure children and visitors are at a safe distance for you work area.
- 10. Keep your workshop childproof.** Use padlocks, Turn off master power switches and remove start switch keys.
- 11. Never leave machine unattended.** Turn power off and wait till machine has come to a complete stop before leaving the machine unattended.
- 12. Make a safe working environment.** Do not use machine in a damp, wet area, or where flammable or noxious fumes may exist.
- 13. Disconnect main power before service machine.** Make sure power switch is in the off position before re-connecting.
- 14. Use correct amperage extension cords.** Undersized extension cords overheat and lose power. Replace extension cords if they become damaged.
- 15. Keep machine well maintained.** Keep blades sharp and clean for best and safest performance. Follow instructions when lubricating and changing accessories.
- 16. Keep machine well guarded.** Make sure guards on machine are in place and are all working correctly.
- 17. Do not overreach.** Keep proper footing and balance at all times.
- 18. Secure workpiece.** Use clamps or a vice to hold the workpiece where practical. Keeping the workpiece secure will free up your hand to operate the machine and will protect hand from injury.
- 19. Check machine over before operating.** Check machine for damaged parts, loose bolts, Keys and wrenches left on machine and any other conditions that may effect the machines operation. Repair and replace damaged parts.
- 20. Use recommended accessories.** Refer to instruction manual or ask correct service officer when using accessories. The use of improper accessories may cause the risk of injury.
- 21. Do not force machinery.** Work at the speed and capacity at which the machine or accessory was designed.
- 22. Use correct lifting practice.** Always use the correct lifting methods when using machinery. Incorrect lifting methods can cause serious injury.
- 23. Lock mobile bases.** Make sure any mobile bases are locked before using machine.
- 24. Allergic reactions.** Certain metal shavings and cutting fluids may cause an allergic reaction in people and animals, especially when cutting as the fumes can be inhaled. Make sure you know what type of metal and cutting fluid you will be exposed to and how to avoid contamination.
- 25. Call for help.** If at any time you experience difficulties, stop the machine and call you nearest branch service department for help.

WARNING

Swage & Jenny Machine Safety Instructions

Machinery House
requires you to read this entire Manual before using this machine.

- 1. Maintenance.** Make sure the Swage & Jenny is turned off and disconnect from the main power supply and make sure all moving parts have come to a complete stop before any inspection, adjustment or maintenance is carried out.
- 2. Swage & Jenny Condition.** A Swage & Jenny must be maintained for a proper working condition. Never operate a Swage & Jenny that has damaged or worn parts. Scheduled routine maintenance should be performed on a scheduled basis.
- 3. Roll Condition.** Never operate a Swage & Jenny with a damaged or badly worn rolls. Replace if required. Rolls should never be greased or lubricated as rolls will slip the material and will not bend.
- 4. Roll Direction.** Be aware of the correct rotational axis of the motor when a qualified electrician connects the Machine.
- 5. Hand Hazard.** Keep hands and fingers clear from moving parts. Serious injury can occur if hand or finger tips get pinched by rolls and can be dragged into machine.
- 6. Personal Protection.** Gloves, safety glasses and safety hat are recommended during operation.
- 7. Avoiding Entanglement.** Swage & Jenny guards must be used at all times. Tie up long hair and use the correct hair nets to avoid any entanglement with the Swage & Jenny moving parts.
- 8. Understand the machines controls.** Make sure you understand the use and operation of all controls.
- 9. Trained Operator.** This machine must be operated by authorized and trained personnel.
- 10. Power outage.** In the event of a power failure during use of the machine, turn off all switches to avoid possible sudden start up once power is restored.
- 11. Work area hazards.** Keep the area around the Swage & Jenny clean from oil, tools, chips. Pay attention to other persons in the area and know what is going on around the area to ensure unintended accidents.
- 12. Guards.** Do not operate Swage & Jenny without the correct guards in place. Necessary guards protect you from injuries by gearbox, motors and other moving gears & parts. The only other area which needs to be carefully monitored during use is the rotational area of the rolls.
- 13. Material condition.** Material must be clean of oil and dry. Oily material can slip and will not bend.
- 14. Material hardness.** Make sure your hardness is the same throughout the material, we recommend that you use certified material. Never bend hard steel, glass or fragile material on this machine.
- 15. Feeding material.** Making a tight bend in one pass is not possible. So you need several passes before you can achieve a certain radius. Tighter curves and full radius always need more passes.
- 16. Stopping the Rolls.** Do not stop or slow the rolls with your hand or workpiece. Allow the Swage & Jenny to stop on its own.
- 17. Emergency stop.** Use the emergency stop button in case of any emergency.
- 18. Hearing protection and hazards.** Always wear hearing protection as noise generated from machine and workpiece can cause permanent hearing loss over time.
- 19. Call for help.** If at any time you experience difficulties, stop the machine and call you nearest branch service department for help.

PLANT SAFETY PROGRAM

NEW MACHINERY HAZARD IDENTIFICATION, ASSESSMENT & CONTROL

Swage & Jenny Machine

Developed in Co-operation Between A.W.I.S.A and Australia Chamber of Manufactures
This program is based upon the Safe Work Australia, Code of Practice - Managing Risks of Plant in the Workplace (WHSA 2011 No10)

Item No.	Hazard Identification	Hazard Assessment	Risk Control Strategies <small>(Recommended for Purchase / Buyer / User)</small>
A	ENTANGLEMENT CRUSHING	HIGH LOW	Eliminate, avoid loose clothing / Long hair etc. Secure & support work material. Ensure machine is bolted down.
B	CUTTING, STABBING, PUNCTURING.	MEDIUM	Isolate power to machine prior to any checks or maintenance being carried out. Do not adjust or clean until the machine has fully stopped. Wear gloves to prevent cuts from material.
D	SHEARING	MEDIUM	Isolate power to machine when checks or maintenance is being carried out. Make sure all guards are secured shut when machine is on. Hands should be kept clear of moving parts such as rolls etc.
F	STRIKING	MEDIUM	Ensure area is kept clear of material being rolled.
H	ELECTRICAL	MEDIUM	All electrical enclosures should only be opened with a tool that is not to be kept with the machine. Machine should be installed & checked by a Licensed Electrician.
O	OTHER HAZARDS, NOISE.	LOW	Wear hearing protection as required.
Plant Safety Program to be read in conjunction with manufactures instructions			



www.machineryhouse.com.au



www.machineryhouse.co.nz

Authorised and signed by:
Safety officer:

Manager:

[Signature]

Revised Date: 12th March 2012